

Montážní sady pro profilové systémy 30 / 40

pro drážku šířky 6 / 8, sestava s maticí pro T-drážku GN 506

SPECIFIKACE

Typy

- Typ **A**: se šroubem s válcovou hlavou DIN 912
- Typ **B**: se šrouben se zápuštěnou hlavou DIN 7991
- Typ **C**: se šroubem s půlkulatou hlavou ISO 7380
- Typ **D**: se šroubem s nízkou válcovou hlavou DIN 7984

Matice pro T-drážky GN 506 (viz. strana 982)
Ocel

- pozinkovaná, modrý pozink
- Kulička / Pružina, nerezová ocel

Šrouby s válcovou hlavou DIN 912
Šrouby se zápuštěnou hlavou DIN 7991
Šrouby s půlkulatou hlavou ISO 7380
Šrouby s nízkou válcovou hlavou DIN 7984

Pozinkovaná ocel, modrý pozink



INFORMACE

Montážní sady GN 965 umožňují připojení nejrůznějších standardních prvků k běžným profilovým systémům. Každá sada obsahuje jednu matici pro T-drážku GN 506 (viz. strana 982) a jeden šroub.

- Popis a vysvětlení (viz. strana A44)
- Přehled příslušných standardních montážních sad GN 965 (viz. strana A45)

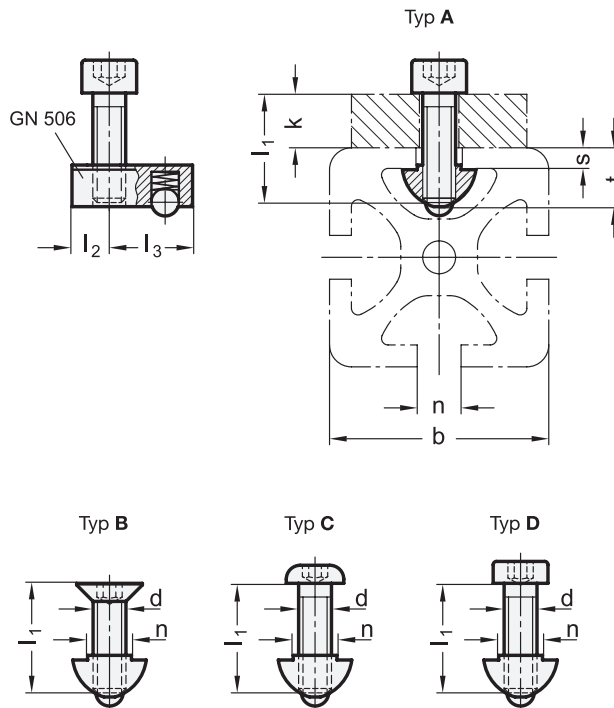

GN 965

Označení	b	n	d	l1	k ≈	l2	l3	s ≈	t ≈	⚖
GN 965-6-M4-10-A	30	6	M4	10	...4	5	12	2.9	8.9	10
GN 965-6-M4-12-A	30	6	M4	12	1...6	5	12	2.9	8.9	12
GN 965-6-M4-16-A	30	6	M4	16	5...10	5	12	2.9	8.9	12
GN 965-6-M5-10-A	30	6	M5	10	...3	5	12	2.9	8.9	6
GN 965-6-M5-12-A	30	6	M5	12	1...5	5	12	2.9	8.9	6
GN 965-6-M5-14-A	30	6	M5	14	3...7	5	12	2.9	8.9	8
GN 965-6-M5-16-A	30	6	M5	16	5...9	5	12	2.9	8.9	9
GN 965-6-M5-18-A	30	6	M5	18	7...11	5	12	2.9	8.9	9
GN 965-6-M5-22-A	30	6	M5	22	11...15	5	12	2.9	8.9	10
GN 965-6-M6-12-A	30	6	M6	12	1...4	5	12	2.9	8.9	9
GN 965-6-M6-14-A	30	6	M6	14	3...6	5	12	2.9	8.9	9
GN 965-6-M6-16-A	30	6	M6	16	5...8	5	12	2.9	8.9	10
GN 965-6-M6-20-A	30	6	M6	20	9...12	5	12	2.9	8.9	10
GN 965-6-M6-25-A	30	6	M6	25	14...17	5	12	2.9	8.9	10
GN 965-8-M4-12-A	40	8	M4	12	...5	7	15	4.6	11.4	10
GN 965-8-M4-14-A	40	8	M4	14	1...7	7	15	4.6	11.4	10
GN 965-8-M4-20-A	40	8	M4	20	7...13	7	15	4.6	11.4	13
GN 965-8-M5-12-A	40	8	M5	12	...4	7	15	4.6	11.4	13
GN 965-8-M5-14-A	40	8	M5	14	1...6	7	15	4.6	11.4	14
GN 965-8-M5-16-A	40	8	M5	16	3...8	7	15	4.6	11.4	14
GN 965-8-M5-18-A	40	8	M5	18	5...10	7	15	4.6	11.4	14
GN 965-8-M5-20-A	40	8	M5	20	7...12	7	15	4.6	11.4	15
GN 965-8-M5-22-A	40	8	M5	22	9...14	7	15	4.6	11.4	15
GN 965-8-M5-25-A	40	8	M5	25	12...17	7	15	4.6	11.4	15
GN 965-8-M6-14-A	40	8	M6	14	1...5	7	15	4.6	11.4	10
GN 965-8-M6-16-A	40	8	M6	16	3...7	7	15	4.6	11.4	10
GN 965-8-M6-18-A	40	8	M6	18	5...9	7	15	4.6	11.4	10
GN 965-8-M6-22-A	40	8	M6	22	9...13	7	15	4.6	11.4	14
GN 965-8-M6-28-A	40	8	M6	28	15...19	7	15	4.6	11.4	20
GN 965-8-M8-14-A	40	8	M8	14	1...4	7	15	4.6	11.4	20
GN 965-8-M8-16-A	40	8	M8	16	3...6	7	15	4.6	11.4	20
GN 965-8-M8-18-A	40	8	M8	18	5...8	7	15	4.6	11.4	21
GN 965-8-M8-20-A	40	8	M8	20	7...10	7	15	4.6	11.4	22
GN 965-8-M8-28-A	40	8	M8	28	15...18	7	15	4.6	11.4	24
GN 965-6-M4-10-B	30	6	M4	10	...4	5	12	2.9	8.9	14
GN 965-6-M5-12-B	30	6	M5	12	1...5	5	12	2.9	8.9	16
GN 965-6-M6-12-B	30	6	M6	12	1...4	5	12	2.9	8.9	18
GN 965-6-M6-14-B	30	6	M6	14	3...6	5	12	2.9	8.9	19
GN 965-6-M6-16-B	30	6	M6	16	5...8	5	12	2.9	8.9	20
GN 965-6-M6-18-B	30	6	M6	18	7...10	5	12	2.9	8.9	20
GN 965-8-M5-14-B	40	8	M5	14	1...6	7	15	4.6	11.4	13
GN 965-8-M6-14-B	40	8	M6	14	1...5	7	15	4.6	11.4	13
GN 965-8-M6-16-B	40	8	M6	16	3...7	7	15	4.6	11.4	13
GN 965-8-M6-18-B	40	8	M6	18	5...9	7	15	4.6	11.4	13
GN 965-8-M6-20-B	40	8	M6	20	7...11	7	15	4.6	11.4	13
GN 965-8-M8-16-B	40	8	M8	16	3...6	7	15	4.6	11.4	18
GN 965-6-M6-14-C	30	6	M6	14	3...6	5	12	2.9	8.9	20
GN 965-8-M6-16-C	40	8	M6	16	3...7	7	15	4.6	11.4	14
GN 965-8-M6-22-C	40	8	M6	22	9...13	7	15	4.6	11.4	20
GN 965-8-M8-16-C	40	8	M8	16	3...6	7	15	4.6	11.4	17
GN 965-8-M8-18-C	40	8	M8	18	5...8	7	15	4.6	11.4	18
GN 965-6-M6-10-D	30	6	M6	10	...3	5	12	2.9	8.9	8
GN 965-8-M6-14-D	40	8	M6	14	1...5	7	15	4.6	11.4	10



Strojní prvky