

Ruční kolečka s aretační přítlačnou podložkou

Technopolymer

MATERIÁL

- Kolečko z technopolymeru na bázi polyamidu (PA) vyztuženého skelnými vlákny, barva černá, matný povrch.
- Závitový čep z nerezové oceli AISI 303, kulové zakončení.
- Přítlačná podložka z technopolymeru na bázi acetalu (POM), barva černá, matný povrch, dodáváno v demontu.

VLASTNOSTI A POUŽITÍ

Kolečka VC.692-SST-p-SV umožňují pevnou aretaci součástí a díky přítlačné podložce nedochází k přímému kontaktu čepu s povrchem, který má být zajištěn.

Kovové pouzdro z nerezové oceli AISI 303 umožňuje použití tohoto kolečka v odvětvích, kde je vyžadováno použití korozivzdorných materiálů.

Příklad použití

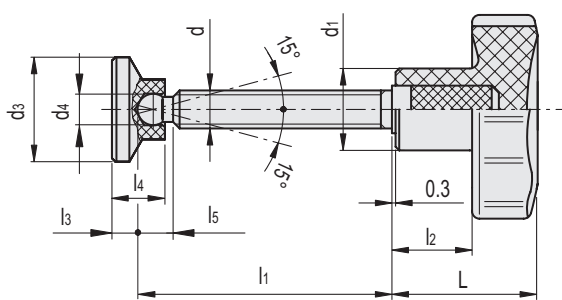
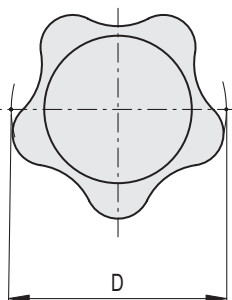
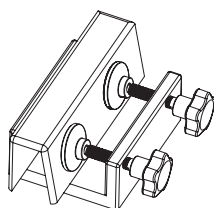

ELESA Original design

STAINLESS STEEL

Kód	Označení	D	d6g	L	d1	d3	d4	l1	l2	l3	l4	l5	Δ
164001	VC.692/25 SST-p-M6x25-SV15	25	M6	20	12	15	4,5	25	10	3,5	7,5	5	16
164003	VC.692/25 SST-p-M6x35-SV15	25	M6	20	12	15	4,5	35	10	3,5	7,5	5	18
164005	VC.692/25 SST-p-M6x45-SV15	25	M6	20	12	15	4,5	45	10	3,5	7,5	5	21
164101	VC.692/32 SST-p-M6x25-SV15	32	M6	22,5	14	15	4,5	25	12,5	3,5	7,5	5	27
164103	VC.692/32 SST-p-M6x35-SV15	32	M6	22,5	14	15	4,5	35	12,5	3,5	7,5	5	29
164105	VC.692/32 SST-p-M6x45-SV15	32	M6	22,5	14	15	4,5	45	12,5	3,5	7,5	5	31
164111	VC.692/32-SST-p-M8x30-SV18	32	M8	22,5	14	18	6	30	12,5	4	9	6	29
164113	VC.692/32-SST-p-M8x40-SV18	32	M8	22,5	14	18	6	40	12,5	4	9	6	31
164115	VC.692/32-SST-p-M8x50-SV18	32	M8	22,5	14	18	6	50	12,5	4	9	6	33
164121	VC.692/32-SST-p-M8x30-SV21	32	M8	22,5	14	21	6	30	12,5	5	10	6	31
164123	VC.692/32-SST-p-M8x40-SV21	32	M8	22,5	14	21	6	40	12,5	5	10	6	33
164125	VC.692/32-SST-p-M8x50-SV21	32	M8	22,5	14	21	6	50	12,5	5	10	6	35
164131	VC.692/32-SST-p-M8x30-SV25	32	M8	22,5	14	25	6	30	12,5	5,5	10,5	6	33
164133	VC.692/32-SST-p-M8x40-SV25	32	M8	22,5	14	25	6	40	12,5	5,5	10,5	6	37
164135	VC.692/32-SST-p-M8x50-SV25	32	M8	22,5	14	25	6	50	12,5	5,5	10,5	6	39
164141	VC.692/32-SST-p-M8x30-SV32	32	M8	22,5	14	32	6	30	12,5	6	11	6	37
164143	VC.692/32-SST-p-M8x40-SV32	32	M8	22,5	14	32	6	40	12,5	6	11	6	39
164145	VC.692/32-SST-p-M8x50-SV32	32	M8	22,5	14	32	6	50	12,5	6	11	6	41
164151	VC.692/32-SST-p-M8x30-SV40	32	M8	22,5	14	40	6	30	12,5	8	13	6	39
164153	VC.692/32-SST-p-M8x40-SV40	32	M8	22,5	14	40	6	40	12,5	8	13	6	41
164155	VC.692/32-SST-p-M8x50-SV40	32	M8	22,5	14	40	6	50	12,5	8	13	6	43

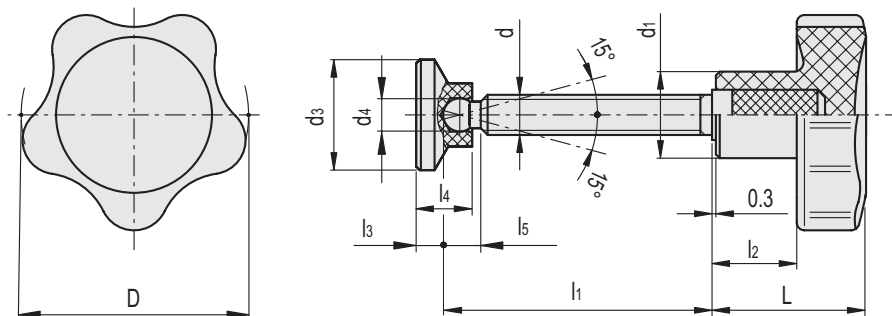
STAINLESS STEEL

Kód	Označení	D	d _g	L	d ₁	d ₃	d ₄	l ₁	l ₂	l ₃	l ₄	l ₅	⚖
164201	VC.692/40-SST-p-M8x30-SV18	40	M8	26	15	18	6	30	14	4	9	6	44
164203	VC.692/40-SST-p-M8x40-SV18	40	M8	26	15	18	6	40	14	4	9	6	46
164205	VC.692/40-SST-p-M8x50-SV18	40	M8	26	15	18	6	50	14	4	9	6	50
164211	VC.692/40-SST-p-M8x30-SV21	40	M8	26	15	21	6	30	14	5	10	6	46
164213	VC.692/40-SST-p-M8x40-SV21	40	M8	26	15	21	6	40	14	5	10	6	48
164215	VC.692/40-SST-p-M8x50-SV21	40	M8	26	15	21	6	50	14	5	10	6	52
164221	VC.692/40-SST-p-M8x30-SV25	40	M8	26	15	25	6	30	14	5.5	10.5	6	48
164223	VC.692/40-SST-p-M8x40-SV25	40	M8	26	15	25	6	40	14	5.5	10.5	6	50
164225	VC.692/40-SST-p-M8x50-SV25	40	M8	26	15	25	6	50	14	5.5	10.5	6	52
164231	VC.692/40-SST-p-M8x30-SV32	40	M8	26	15	32	6	30	14	6	11	6	52
164233	VC.692/40-SST-p-M8x40-SV32	40	M8	26	15	32	6	40	14	6	11	6	54
164235	VC.692/40-SST-p-M8x50-SV32	40	M8	26	15	32	6	50	14	6	11	6	56
164241	VC.692/40-SST-p-M8x30-SV40	40	M8	26	15	40	6	30	14	8	13	6	54
164243	VC.692/40-SST-p-M8x40-SV40	40	M8	26	15	40	6	40	14	8	13	6	56
164245	VC.692/40-SST-p-M8x50-SV40	40	M8	26	15	40	6	50	14	8	13	6	58
164251	VC.692/40 SST-p-M10x35-SV21	40	M10	26	15	21	8	35	14	4	10	7.5	56
164253	VC.692/40 SST-p-M10x45-SV21	40	M10	26	15	21	8	45	14	4	10	7.5	58
164255	VC.692/40 SST-p-M10x55-SV21	40	M10	26	15	21	8	55	14	4	10	7.5	60
164261	VC.692/40 SST-p-M10x35-SV25	40	M10	26	15	25	8	35	14	4.5	10.5	7.5	58
164263	VC.692/40 SST-p-M10x45-SV25	40	M10	26	15	25	8	45	14	4.5	10.5	7.5	60
164265	VC.692/40 SST-p-M10x55-SV25	40	M10	26	15	25	8	55	14	4.5	10.5	7.5	62
164271	VC.692/40 SST-p-M10x35-SV32	40	M10	26	15	32	8	35	14	5	11	7.5	60
164273	VC.692/40 SST-p-M10x45-SV32	40	M10	26	15	32	8	45	14	5	11	7.5	62
164275	VC.692/40 SST-p-M10x55-SV32	40	M10	26	15	32	8	55	14	5	11	7.5	64
164281	VC.692/40 SST-p-M10x35-SV40	40	M10	26	15	40	8	35	14	7	13	7.5	62
164283	VC.692/40 SST-p-M10x45-SV40	40	M10	26	15	40	8	45	14	7	13	7.5	64
164285	VC.692/40 SST-p-M10x55-SV40	40	M10	26	15	40	8	55	14	7	13	7.5	68
164301	VC.692/50-SST-p-M10x35-SV21	50	M10	31	18	21	8	35	17	4	10	7.5	71
164303	VC.692/50-SST-p-M10x45-SV21	50	M10	31	18	21	8	45	17	4	10	7.5	77
164305	VC.692/50-SST-p-M10x55-SV21	50	M10	31	18	21	8	55	17	4	10	7.5	85
164311	VC.692/50-SST-p-M10x35-SV25	50	M10	31	18	25	8	35	17	4.5	10.5	7.5	73
164313	VC.692/50-SST-p-M10x45-SV25	50	M10	31	18	25	8	45	17	4.5	10.5	7.5	79
164315	VC.692/50-SST-p-M10x55-SV25	50	M10	31	18	25	8	55	17	4.5	10.5	7.5	87
164321	VC.692/50-SST-p-M10x35-SV32	50	M10	31	18	32	8	35	17	5	11	7.5	75
164323	VC.692/50-SST-p-M10x45-SV32	50	M10	31	18	32	8	45	17	5	11	7.5	81
164325	VC.692/50-SST-p-M10x55-SV32	50	M10	31	18	32	8	55	17	5	11	7.5	89
164331	VC.692/50-SST-p-M10x35-SV40	50	M10	31	18	40	8	35	17	7	13	7.5	77
164333	VC.692/50-SST-p-M10x45-SV40	50	M10	31	18	40	8	45	17	7	13	7.5	83
164335	VC.692/50-SST-p-M10x55-SV40	50	M10	31	18	40	8	55	17	7	13	7.5	91

