

Příslušenství pro rychloupínací moduly

GN 910.2 a GN 910.3

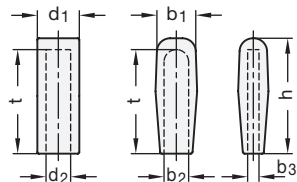

Rukojeti

GN 910.5

| Označení | Velikost | b1 | d1 | b2 | d2 | b3 | h | t | ⚖ |
|---------------|----------|----|----|----|----|----|-----|-----|----|
| GN 910.5-220 | 220 | 22 | - | 13 | - | 5 | 60 | 55 | 12 |
| GN 910.5-440 | 440 | 31 | - | 20 | - | 8 | 86 | 77 | 22 |
| GN 910.5-850 | 850 | - | 30 | - | 22 | - | 119 | 112 | 50 |
| GN 910.5-1540 | 1540 | - | 34 | - | 25 | - | 119 | 112 | 54 |

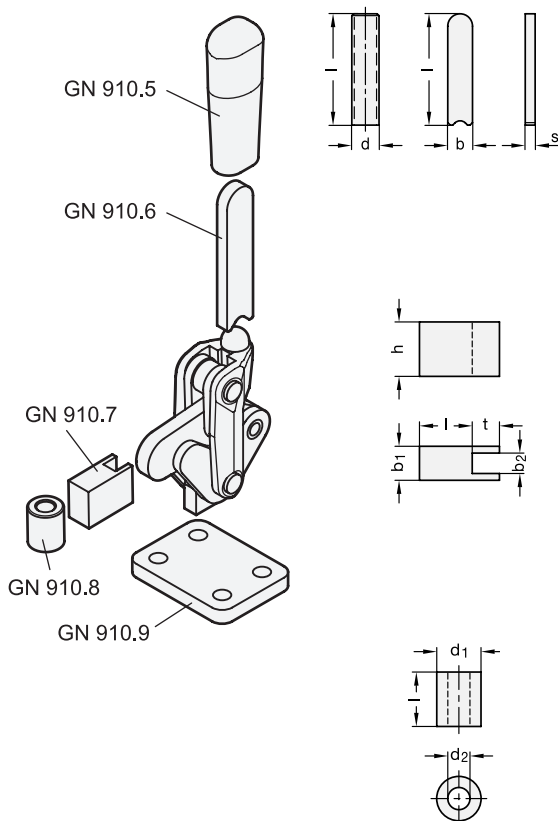

Ovládací páky

GN 910.6

| Označení | Velikost | b | d | l | s | ⚖ |
|---------------|----------|----|----|-----|---|-----|
| GN 910.6-220 | 220 | 13 | - | 60 | 5 | 31 |
| GN 910.6-440 | 440 | 20 | - | 90 | 8 | 108 |
| GN 910.6-850 | 850 | - | 22 | 122 | - | 122 |
| GN 910.6-1540 | 1540 | - | 25 | 138 | - | 187 |

Prodloužení upínacích ramen

GN 910.7

| Označení | Velikost | b1 | b2 | h | l | t | ⚖ |
|---------------|----------|----|------|----|------|-----|-----|
| GN 910.7-220 | 220 | 10 | 6 | 16 | 15.5 | 6.5 | 23 |
| GN 910.7-440 | 440 | 15 | 10 | 24 | 16 | 8 | 76 |
| GN 910.7-850 | 850 | 20 | 12 | 30 | 22.1 | 15 | 130 |
| GN 910.7-1540 | 1540 | 25 | 16.2 | 35 | 23.5 | - | 204 |

Pouzdra

GN 910.8

| Označení | Velikost | d1 | d2 | l | ⚖ |
|---------------|----------|----|------|----|-----|
| GN 910.8-220 | 220 | 13 | 6.5 | 16 | 13 |
| GN 910.8-440 | 440 | 20 | 10.5 | 24 | 42 |
| GN 910.8-850 | 850 | 24 | 12.5 | 30 | 76 |
| GN 910.8-1540 | 1540 | 32 | 16.5 | 35 | 161 |

Základové desky

GN 910.9

| Označení | Velikost | d | l1 | l2 | m1 | m2 | s | ⚖ |
|---------------|----------|------|-----|----|----|----|----|-----|
| GN 910.9-220 | 220 | 6.5 | 48 | 36 | 32 | 20 | 6 | 74 |
| GN 910.9-440 | 440 | 8.5 | 65 | 54 | 45 | 30 | 8 | 205 |
| GN 910.9-850 | 850 | 10.5 | 75 | 75 | 55 | 55 | 10 | 400 |
| GN 910.9-1540 | 1540 | 12.5 | 100 | 90 | 65 | 65 | 10 | 657 |